



**STRUTTURA**

**STRUCTURE**

**STRUCTURE**

**STRUKTUR**

**GHB**



Struttura

**GHB**

Modello / Model / Modèle / Model

**Tutti / All / Tous / Allen**

Particolare / Part / Part / Einzelheit

**TELAIO COMPLETO / COMPLETE FRAME**

**CHASSIS COMPLET / KOMPL. RAHMEN**

LATO TURBINA TURBINE SIDE  
COTE TURBINE TURBINENSEITE

LATO CATENA CHAIN SIDE  
COTE CHAINE KETTENSEITE

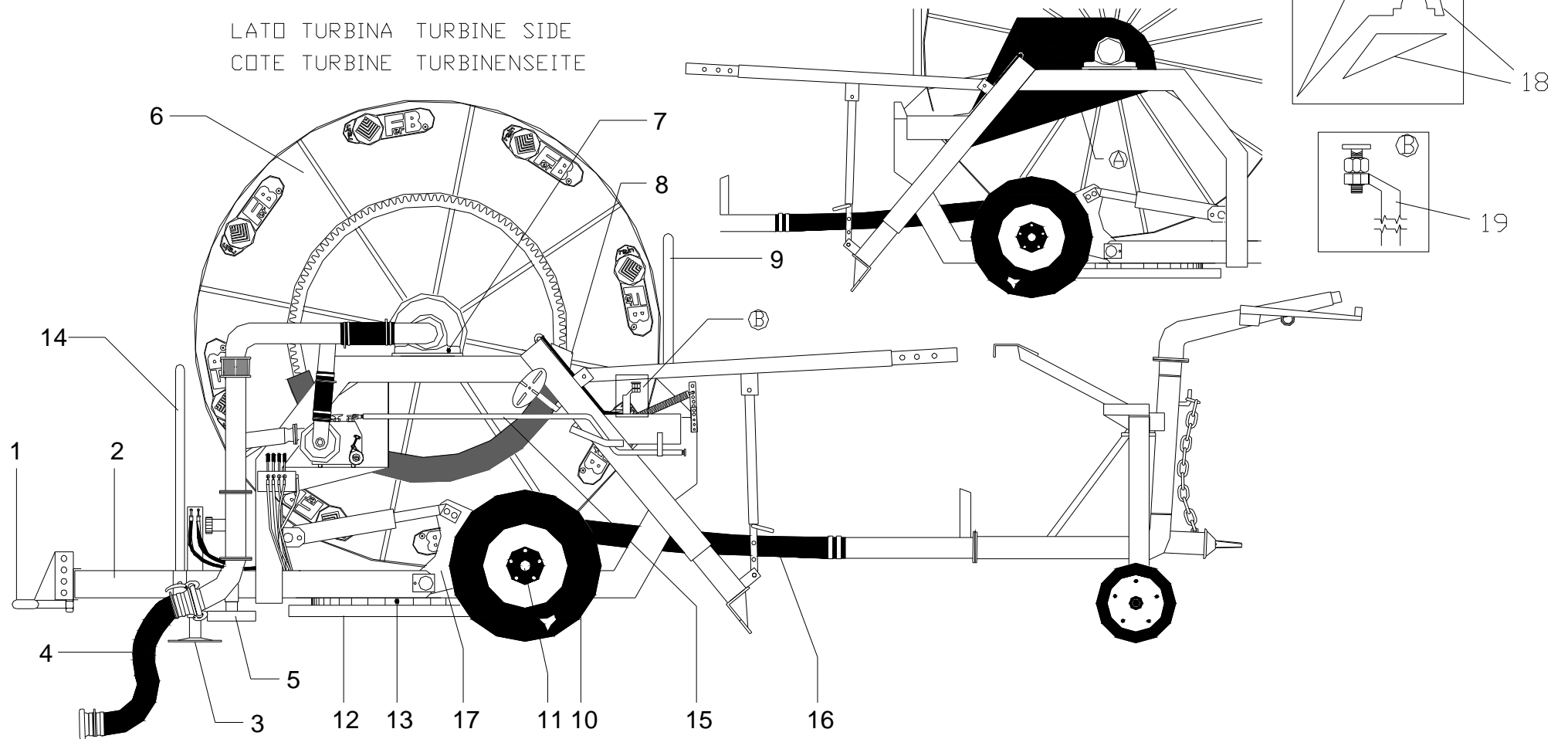



Struttura

**GHB**

Modello / Model / Modèle / Model

**Tutti / All / Tous / Allen**

Particolare / Part / Part / Einzelheit

**TELAIO COMPLETO / COMPLETE FRAME**

**CHASSIS COMPLET / KOMPL. RAHMEN**

Fig.	Cod.	Q.tà	Descrizione	Description	Description	Beschreibung	Applicazione Application Applikation
1	50-01-00183	1	Occhione	Tow-eye	Tête d'attelage	Zugöse	
2	50-01-00568	1	Telaio	Frame	Châssis	Rahmen	
3	50-01-00190	1	Piedino alza timone PIP 06	Tow-bar staker leg PIP 06	Béquille sur timon PIP 06	Zugschaft PIP 06	
4	50-01-00607	1	Manichetta flessibile 120x133	Flexible hose 120x133	Tuyau flexible 120x133	Anspeisschlauch 120x133	
5	50-01-00194	2	Piedino per ala	Boom staker leg	Béquilles pour rampe arrosage	Zugschaft für Düsenwagen	
6	50-01-00592	1	Rullo mod. 6	Drum mod. 6	Bobine mod. 6	Trommel mod. 6	
6	50-01-00593	1	Rullo mod. 6.1	Drum mod. 6.1	Bobine mod. 6.1	Trommel mod. 6.1	
6	50-01-00594	1	Rullo mod. 6.2	Drum mod. 6.2	Bobine mod. 6.2	Trommel mod. 6.2	
7	50-01-00238	1	Supporto rullo Ø120 BASE	Drum support Ø120 BASE	Palier bobine Ø120 BASE	Trommelstehlager Ø120 BASE	Ø110-125-150
7	50-01-00239	1	Supporto rullo Ø120 R5	Drum support Ø120 R5	Palier bobine Ø120 R5	Trommelstehlager Ø120 R5	Ø140
8	50-01-00330	1	Protezione corona	Crown guard	Protection couronne	Zahnkranz Gehäuse	
9	50-01-00200	1	Snodo barra	Bar joint	Articulation barre débrayage	Abschaltbügel	
10	50-01-00273	2	Ruota 11.5/80-15.3 pr16 6F	Wheel 11.5/80-15.3 pr16 6F	Roue 11.5/80-15.3 pr16 6F	Rad 11.5/80-15.3 pr16 6F	110/500-110/550-125/450
10	50-01-00274	2	Ruota 13.0/65-18 pr16 6F	Wheel 13.0/65-18 pr16 6F	Roue 13.0/65-18 pr16 6F	Rad 13.0/65-18 pr16 6F	110/600-125/500-140/350-140/600
11	50-01-00290	2	Mozzo Q70 6F L180	Hub Q70 6F L180	Moyeu Q70 6F L180	Steckachse Q70 6F L180	
12	50-01-00447	1	Porta-ralla	Turn table support	Palier tourelle	Drehkranzstehlager	
13	50-01-00445	1	Ralla	Turn table	Tourelle	Drehkranz	
14	50-01-00450	1	Proteggi tubo	Hose protection	Protection tuyau	Schlauchschutz	
15	50-01-00214	1	Leva disinnesto riduttore	Gearbox release lever	Levier débrayage réducteur	Getriebe Abschaltungshebel	
16		1	Tubo PE media densità*	Medium density PE hose *	Tuyau en PE médium densité *	PE Rohr *	
17	50-01-00685	2	Supporto ruota con mozzo	Wheel support with hub	Palier roue avec moyeu	Radhalter mit Nabe	
18	50-01-00698	1	Protezione catena	chain protection	protection chaîne	Kettenschutz	
19	50-01-00701	1	Battuta carica carrello	trolley lifter stop point	point d'arrêt du charge-chariot	Anschlag Hebevorrichtung	

\* Comunicare modello e matricola della macchina / State machine model and serial number / Spécifier modèle et numéro de série de la machine / Modell und Matrikelnummer der Maschine spezifizieren



Struttura

**GHB**

Modello / Model / Modèle / Model

**Tutti / All / Tous / Allen**

Particolare / Part / Part / Einzelheit

**TURBINA TD 260 / TURBINE TD 260**

**TURBINE TD 260 / TURBINE TD 260**

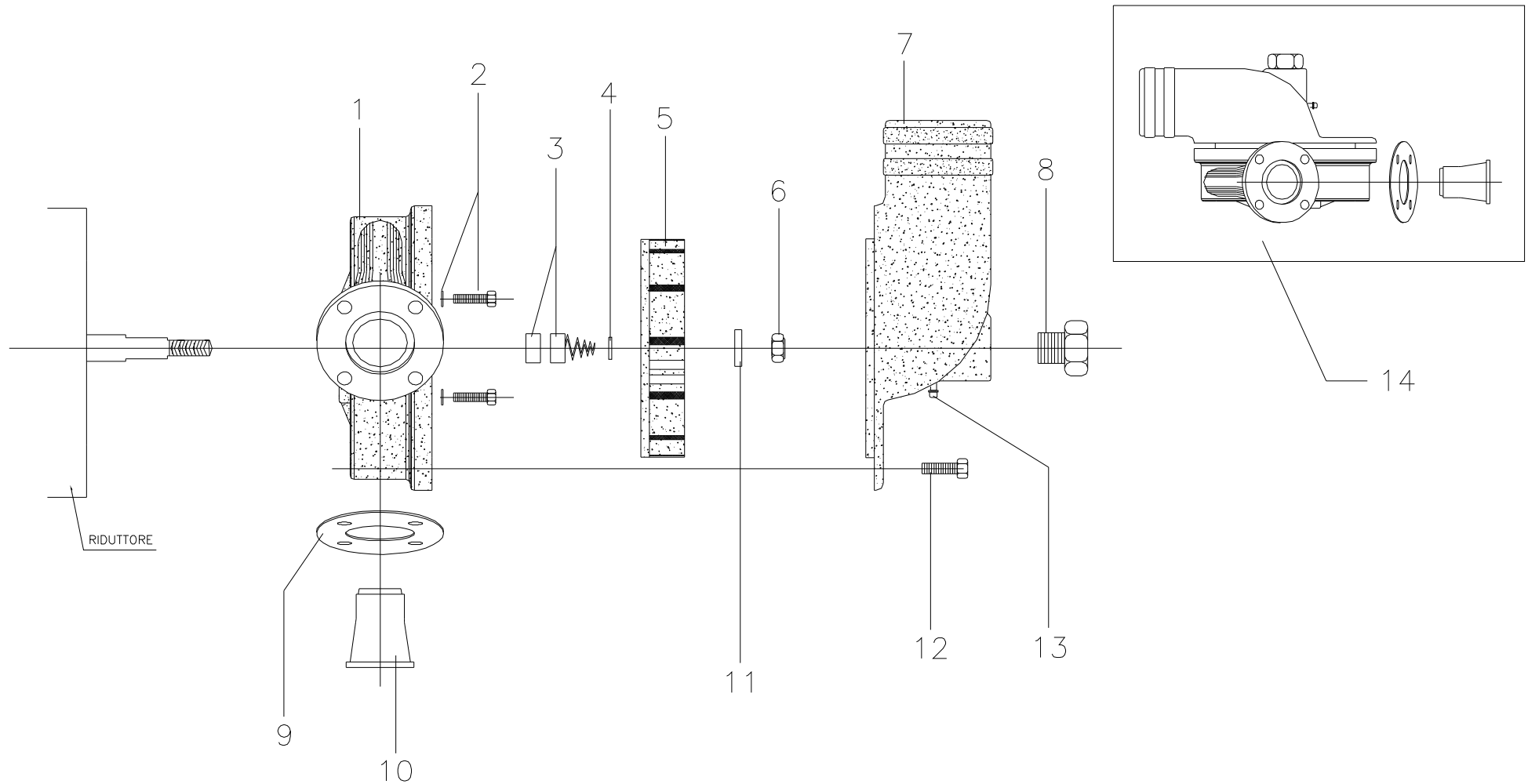



Struttura

**GHB**

Modello / Model / Modèle / Model

**Tutti / All / Tous / Allen**

Particolare / Part / Part / Einzelheit

**TURBINA TD 260 / TURBINE TD 260**

**TURBINE TD 260 / TURBINE TD 260**

Fig.	Cod.	Q.tà	Descrizione	Description	Description	Beschreibung	Applicazione Application Applikation
1	50-01-00062	1	Cassa turbina 260	Turbine box 260	Caisse turbine 260	Turbinengehäuse 260	
2	50-01-00090	4	Vite 8x35 T.C.E.I. + rondella in rame	Screw 8x35 T.C.E.I. + washer	Vis 8x35 T.C.E.I. + rondelle	Schraube 8x35 T.C.E.I. + Scheibe	
3	50-01-00073	1	Tenuta Roten Ø18	Roten seal Ø18	Joint Roten Ø18	Roten Gleitringdichtung Ø18	
4	50-01-00075	1	Spessore 15x21x1,2	Washer 15x21x1,2	Epaisseur 15x21x1,2	Ring 15x21x1,2	
5	50-01-00065	1	Girante 260	Impeller 260	Roue tournante 260	Turbinenlaufrad 260	
6	50-01-00077	1	Dado autobloccante M14	Self-locking nut M14	Ecrou autobloquant M14	Selbstbefestigungsm. M14	
7	50-01-00070	1	Coperchio turbina 260	Turbine guard 260	Protection turbine 260	Lagerdeckel i. Gehäuse 260	
8	50-01-00079	1	Tappo in ottone	Cap	Bouchon	Kupferschraube	
9	50-01-00101	1	Guarnizione ugello turbina	Turbine nozzle gasket	Joint pour buse turbine	Turbinendüsedichtung	
10	50-01-00097	1	Boccaglio turbina Ø32	Turbine nozze Ø32	Buse turbine Ø32	Turbinendüse Ø32	Ø110
10	50-01-00098	1	Boccaglio turbina Ø34	Turbine nozze Ø34	Buse turbine Ø34	Turbinendüse Ø34	Ø125-140-150
11	50-01-00086	1	Fermo 260	Catch 260	Arrêt 260	Halter 260	
12	50-01-00089	11	Vite 10x35 T.C.E.I. rondella Ø10	Screw 10x35 T.C.E.I. + washer Ø10	Vis 10x35 T.C.E.I. +rondelle Ø10	Schraube 10x35 T.C.E.I. + Scheibe Ø10	
13	50-01-00081	1	Valvola di scarico 1/4"	Outlet valve 1/4"	Vanne de décharge 1/4"	Unterdruckabschaltventil 1/4"	
14	50-01-00107	1	Turbina completa mod. 260	Complet turbine mod. 260	Turbine complète mod. 260	Turbine kompl. Mod. 260	



Struttura

**GHB**

Modello / Model / Modèle / Model

**Tutti / All / Tous / Allen**

Particolare / Part / Part / Einzelheit

**PERCORSO ACQUA / WATER PIPEWORK**

**PARCOURS de l'EAU / EINLAUFVERROHRUNG**

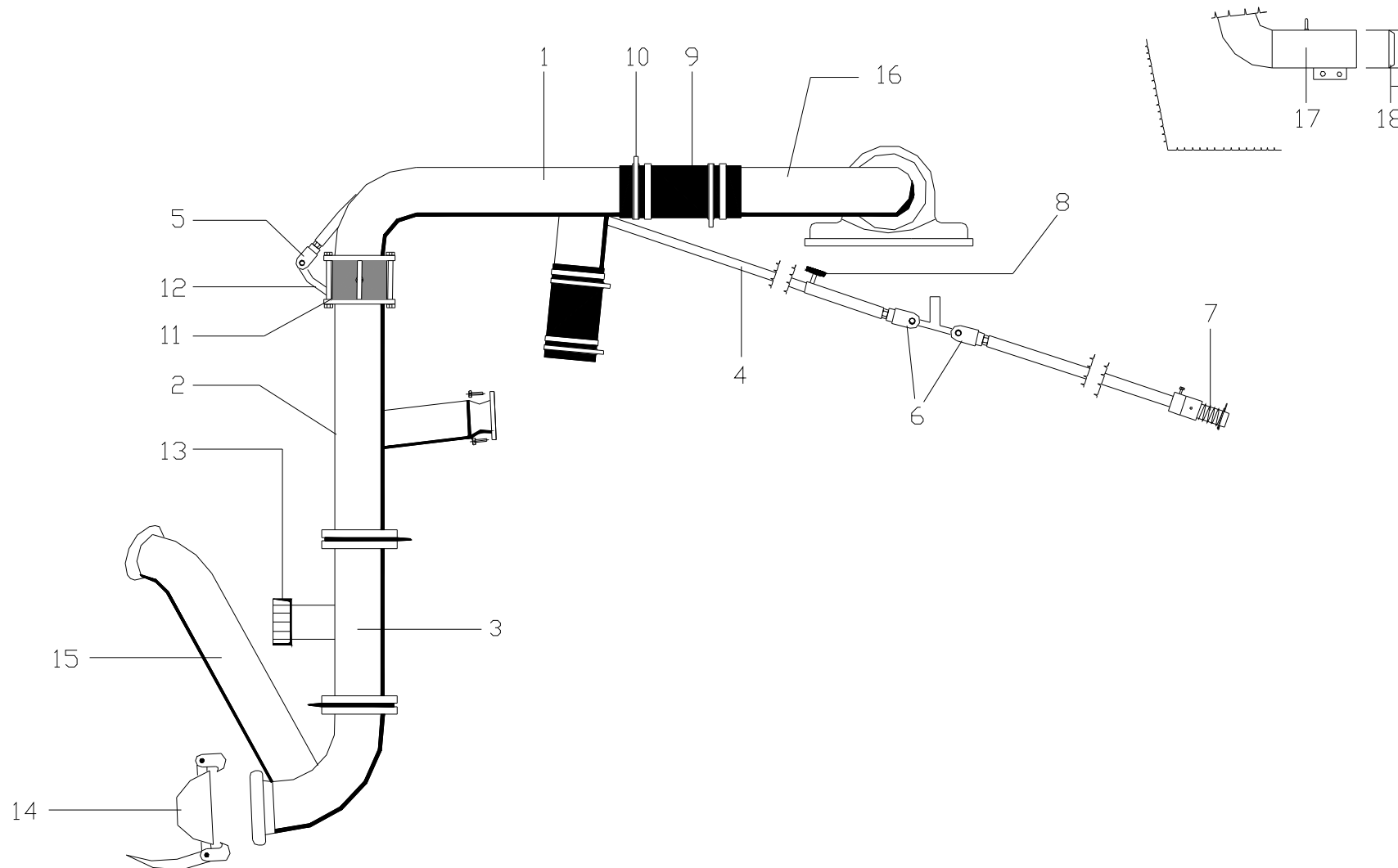



Struttura

**GHB**

Modello / Model / Modèle / Model

**Tutti / All / Tous / Allen**

Particolare / Part / Part / Einzelheit

**PERCORSO ACQUA / WATER PIPEWORK**

**PARCOURS de l'EAU / EINLAUFVERROHRUNG**

Fig.	Cod.	Q.tà	Descrizione	Description	Description	Beschreibung	Applicazione Application Applikation
1	50-01-00009	1	Percorso acqua sopraturbina	Pipe work up	Parcours de l'eau sur turbine	Verrohrung über Turbine	
2	50-01-00018	1	Percorso acqua sottoturbina	Pipe work bottom	Parcours de l'eau sous turbine	Verrohrung unter Turbine	
3	50-01-00024	1	Tronchetto percorso acqua	Pipe work section	Section du parcours de l'eau	Verrohrungsstrecke	
4	50-01-00222	1	Leva regolatore by-pass	By-pass adjusting lever	Levier régulateur by-pass	By-pass Verstellbarhebel	
5	50-01-00255	1	Forcella Ø8 lunga con serraggio	Fork Ø8	Fourchette Ø8	Gabel Ø8	
6	50-01-00254	2	Forcella Ø8 corta con serraggio	Fork Ø8	Fourchette Ø8	Gabel Ø8	
7	50-01-00293	1	Molla con pos-85	Spring	Ressort	Feder	
8	50-01-00296	1	Pomello Ø40 8x15	Hand-grip Ø40 8x15	Bouton Ø40 8x15	Knopf Ø40 8x15	
9	50-01-00051	2	Tubo in gomma Ø120 mt 0,30	Rubber hose Ø120 mt 0,30	Tuyau en caoutchouc Ø120 mt 0,30	Schlauch Ø120 mt 0,30	
10	50-01-00253	8	Fascette 131x139	Clamp 131x139	Bande 131x139	Schelle 131x139	
11	50-01-00057	1	Valvola by-pass 4"	By-pass valve 4"	Vanne by-pass 4"	By-pass Ventil 4"	
12	50-01-00225	1	Regolatore By-pass	By-pass adjuster	Régulateur By-pass	By-pass Verstellung	
13	50-01-00052	1	Tappo esagonale Ø60	Hexagonal cap Ø60	Bouchon hexagonal Ø60	Sechseckig Kupfer Ø60	
14	50-01-00521	1	Tappo Bauer Ø133	Bauer cap Ø133	Bouchon Bauer Ø133	Bauer Kupfer Ø133	
15	50-01-00024	1	Traversa percorso acqua	Pipe work crossbar	Traverse du parcours de l'eau	Kreuzstange Verrohrung	
16	50-01-00619	1	Tenuta con curva	Seal with elbow	Joint avec courbe	Dichtung mit Bogen	
17	50-01-00036	1	Tenuta acqua Ø120	Seal-pipe Ø120	Tube à étanche d'eau Ø120	Dichtungsrohr Ø120	
18	50-01-00044	1	Guarnizione LOM+OR 832 Ø120	LOM+OR gasket 832 Ø120	Garniture LOM+OR 832 Ø120	LOM+OR Dichtung 832 Ø120	



Struttura

**GHB**

Modello / Model / Modèle / Model

**Tutti / All / Tous / Allen**

Particolare / Part / Part / Einzelheit

**ACCOPPIAMENTO RIDUTTORE - CORONA DENTATA / GEARBOX - TOOTHED CROWN ASSEMBLY**

**GROUP REDUCTEUR - COURONNE / GETRIEBE-KEILRIEMENSCH. - ZAHNKRANZ AGGREGAT**

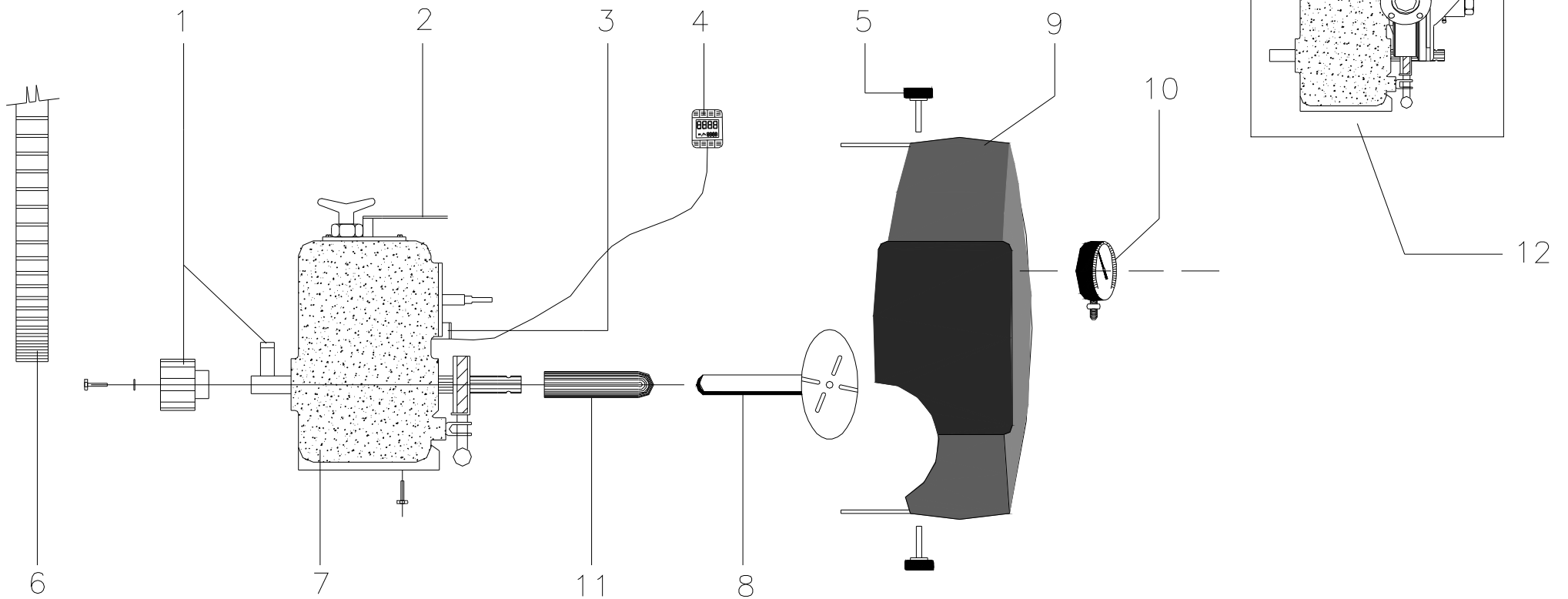





Struttura

**GHB**

Modello / Model / Modèle / Model

**Tutti / All / Tous / Allen**

Particolare / Part / Part / Einzelheit

**ACCOPIAMENTO RIDUTTORE - CORONA DENTATA / GEARBOX - TOOTHED CROWN ASSEMBLY**

**GROUP REDUCTEUR - COURONNE / GETRIEBE-KEILRIEMENSCH. - ZAHNKRANZ AGGREGAT**

Fig.	Cod.	Q.tà	Descrizione	Description	Description	Beschreibung	APPLICAZIONE APPLICATION APPLIKATION
1	50-01-00313	1	Pignone con chiavetta Z11 M8,5 Ø40	Pinion with key Z11 M8,5 Ø40	Pignon avec clef Z11 M8,5 Ø40	Antriebzahnrad Z11 M8,5 Ø40	
2	50-01-00224	1	Disinnesto riduttore	Gearbox release	Débrayage réducteur	Getriebe Abschaltung	
3	50-01-00335	1	Magnete con blocco in PVC	Magnet with PVC block	Aimant avec bloc en PVC	Magnet mit PVC Block	
4	50-01-00336	1	Contametri digitale	Digital counter-meters	Compte-metres digital	Digital Meterzähler	
5	50-01-00296	3	Pomello Ø40 8x15	Hand-grip Ø40 8x15	Bouton Ø40 8x15	Knopf Ø40 8x15	
6	50-01-00323	1	Corona dentata 2060	Toothed crown 2060	Couronne 2060	Zahnkranz 2060	
7	50-01-00306	1	Riduttore D-742 4 velocità	Gearbox D-742 4 speed	Réducteur D-742 4 vitesses	Getriebe D-742 4 Geschwind.	
8	50-01-00337	1	Volantino	Hand wheel	Volant	Handrad	
9	50-01-00334	1	Protezione turbina	Turbine guard	Protection turbine	Turbinegehäuse	
10	50-01-00339	1	Manometro alla glicerina	Manometer	Manomètre	Manometer	
11	50-01-00338	1	Cappuccio PDF	Pto cap	Capuchon prise de forse	Haube	
12	50-01-00680	1	Turboriduttore	Gearbox+turbine	Réducteur+turbine	Getriebe+Turbine	



Struttura

**GHB**

Modello / Model / Modèle / Model

**Tutti / All / Tous / Allen**

Particolare / Part / Part / Einzelheit

**ANCORAGGIO E SOLLEVAMENTO CARRELLO / TROLLEY FIXING AND LIFTING**

**MOUILLAGE ET CHARGEMENT CHARIOT / STATIVVERANKERUNG UND HEBEN**

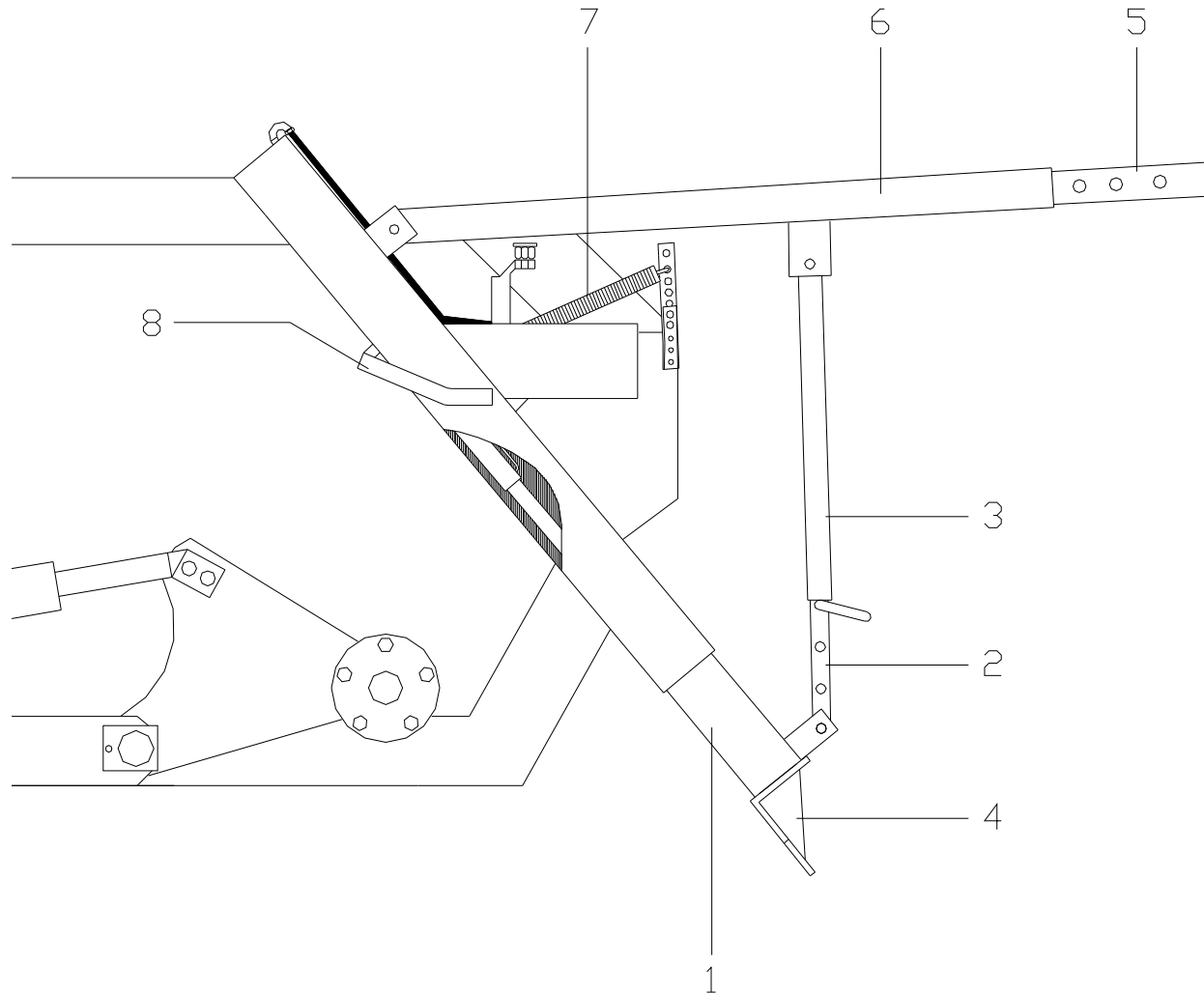



Struttura

**GHB**

Modello / Model / Modèle / Model

**Tutti / All / Tous / Allen**

Particolare / Part / Part / Einzelheit

**ANCORAGGIO E SOLLEVAMENTO CARRELLO / TROLLEY FIXING AND LIFTING**

**MOUILLAGE ET CHARGEMENT CHARIOT / STATIVVERANKERUNG UND HEBEN**

Fig.	Cod.	Q.tà	Descrizione	Description	Description	Beschreibung	Applicazione Application Applikation
1	50-01-00344	2	Sfilabile interno di stazionamento	Internal staker leg	Béquille intérieure	Zugshaftinnenseite	
2	50-01-00349	2	Sfilabile verticale interno	Vertical internal leg	Béquille interieure verticale	Zugshaftinnenseite vertikal	
3	50-01-00350	2	Sfilabile verticale esterno	Vertical external leg	Béquille exterieure verticale	Zugshaftaussenseite vertikal	
4	50-01-00348	2	Vanghetta	Spade	Bêche	Spaten	
5	50-01-00360	1	Carica carrello interno	Internal trolley lifter	Chargeur du chariot intérieur	Innenhebevorrichtung	
6	50-01-00361	1	Carica carrello esterno	External trolley lifter	Chargeur du chariot extérieur	Außenhebevorrichtung	
7	50-01-00292	1	Molla 200x38x4	Spring 200x38x4	Ressort 200x38x4	Feder 200x38x4	
8	50-01-00365	1	Cricchetto	Jack	Cric	Sperrklinke	



Struttura

**GHB**

Modello / Model / Modèle / Model

**Tutti / All / Tous / Allen**

Particolare / Part / Part / Einzelheit

**BARRA di SCORRIMENTO / SLIDING BAR**

**BARRE de ECOULEMENT / GLEITUNGSTANGE**

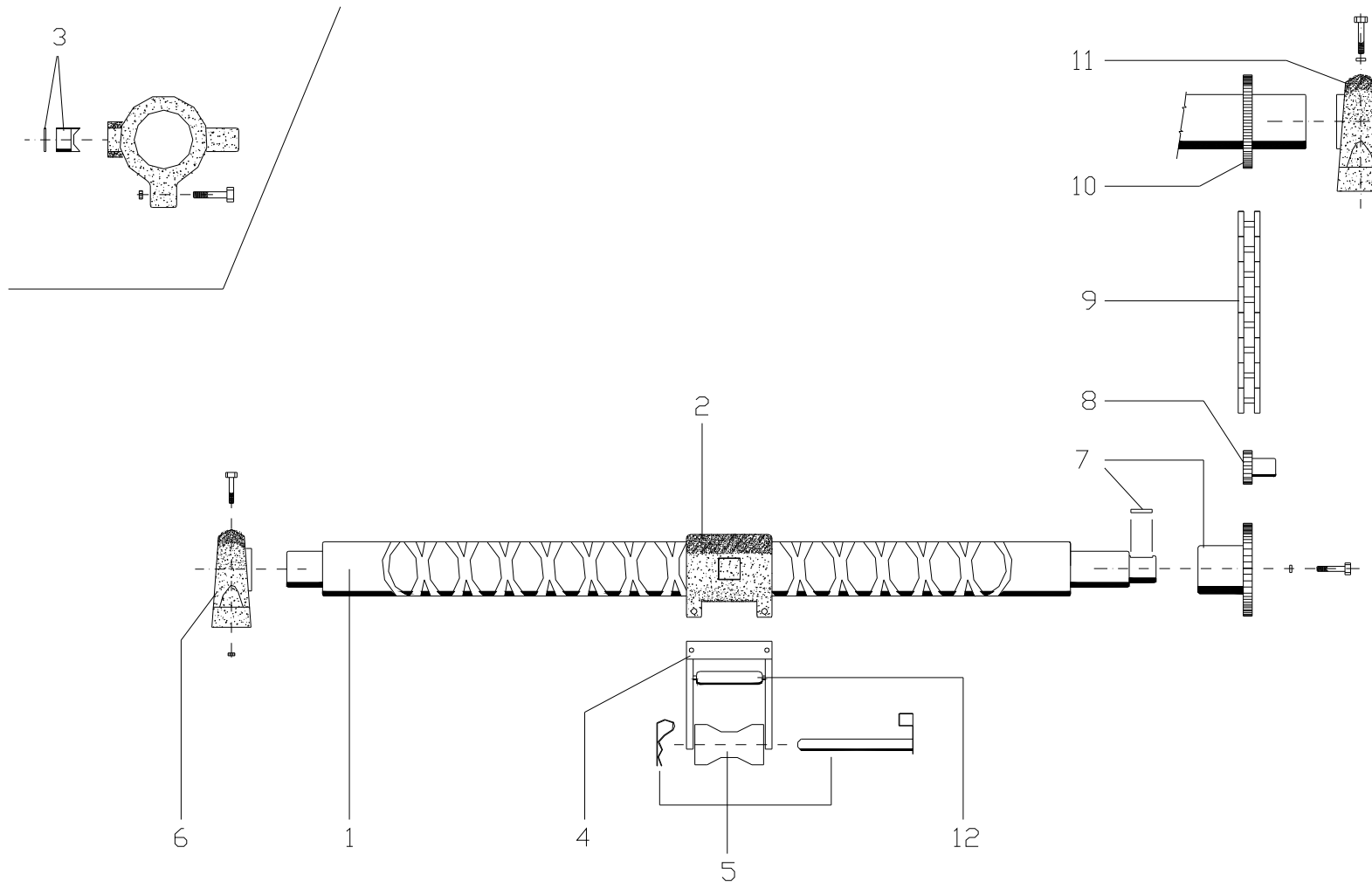



Struttura

**GHB**

Modello / Model / Modèle / Model

**Tutti / All / Tous / Allen**

Particolare / Part / Part / Einzelheit

**BARRA di SCORRIMENTO / SLIDING BAR**

**BARRE de ECOULEMENT / GLEITUNGSTANGE**

Fig.	Cod.	Q.tà	Descrizione	Description	Description	Beschreibung	Applicazione Application Applikation
1	50-01-00113	1	Barra di scorrimento L 1885	Sliding bar L 1885	Barre d'écoulement L 1885	Gleitungsstange L 1885	
2	50-01-00119	1	Blocco di scorrimento	Sliding block	Bloc d'écoulement	Gleitungsblock	
3	50-01-00122	1	Nottolino Ø 40 mod. 2	Pawl Ø 40 mod. 2	Taquet Ø 40 mod. 2	Klinke Ø 40 Mod. 2	
4	50-01-00147	1	Supporto entrata tubo PE	PE hose inlet support	Palier entrée tuyau PE	Spulwagenrahmen	
5	50-01-00130	1	Rocchetto in nylon	Nylon reel	Bobine en nylon	Nylon Spule	
6	50-01-00230	2	Supporto UCP 208	UCP 208 support	Palier UCP 208	UCP 208 Stehlager	
7	50-01-00175	1	Pignone 5/8 Z14 Ø30	Pinion 5/8 Z14 Ø30	Pignon 5/8 Z14 Ø30	Kettenrad 5/8 Z14 Ø30	Ø110-125
7	50-01-00173	1	Pignone 5/8 Z11 Ø30	Pinion 5/8 Z11 Ø30	Pignon 5/8 Z11 Ø30	Kettenrad 5/8 Z11 Ø30	Ø140
7	50-01-00174	1	Pignone 5/8 Z12 Ø30	Pinion 5/8 Z12 Ø30	Pignon 5/8 Z12 Ø30	Kettenrad 5/8 Z12 Ø30	Ø150
8	50-01-00123	1	Tendicatena 5/8	Chain stretcher 5/8	Tendeur de chaîne 5/8	Kettenspanner 5/8	
9	50-01-00124	mt 4	Catena 5/8	Chain 5/8	Chaîne 5/8	Kette 5/8	
10	50-01-00163	1	Corona 5/8 Z35 Ø142	Crown 5/8 Z35 Ø142	Couronne 5/8 Z35 Ø142	Zahnkranz 5/8 Z35 Ø142	Ø110-140
10	50-01-00164	1	Corona 5/8 Z40 Ø142	Crown 5/8 Z40 Ø142	Couronne 5/8 Z40 Ø142	Zahnkranz 5/8 Z40 Ø142	Ø125
10	50-01-00165	1	Corona 5/8 Z41 Ø142	Crown 5/8 Z41 Ø142	Couronne 5/8 Z41 Ø142	Zahnkranz 5/8 Z41 Ø142	Ø150
11	50-01-00238	1	Supporto rullo Ø120 BASE	Drum support Ø120 BASE	Palier bobine Ø120 BASE	Trommelstehlager Ø120 BASE	Ø110-125-150
11	50-01-00239	1	Supporto rullo Ø120 R5	Drum support Ø120 R5	Palier bobine Ø120 R5	Trommelstehlager Ø120 R5	Ø140
12	50-01-00134	1	Rocchetto in ferro Ø32 L145	Iron reel Ø32 L145	Bobine en fer Ø32 L145	Eisenspule Ø32 L145	



Struttura

**GHB**

Modello / Model / Modèle / Model

**Tutti / All / Tous / Alle**

Particolare / Part / Part / Einzelheit

**CARRELLO / TROLLEY**

**CHARIOT / STATIV**

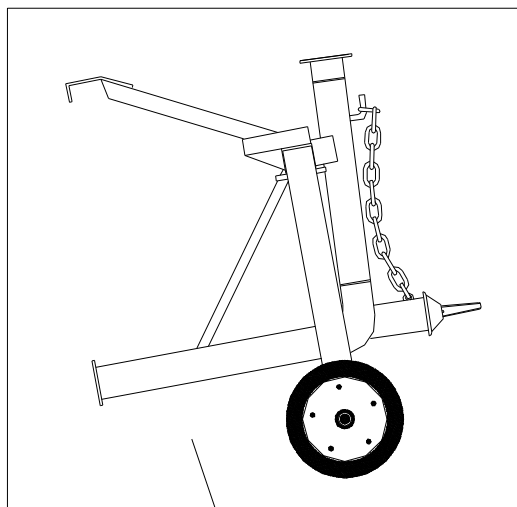

10

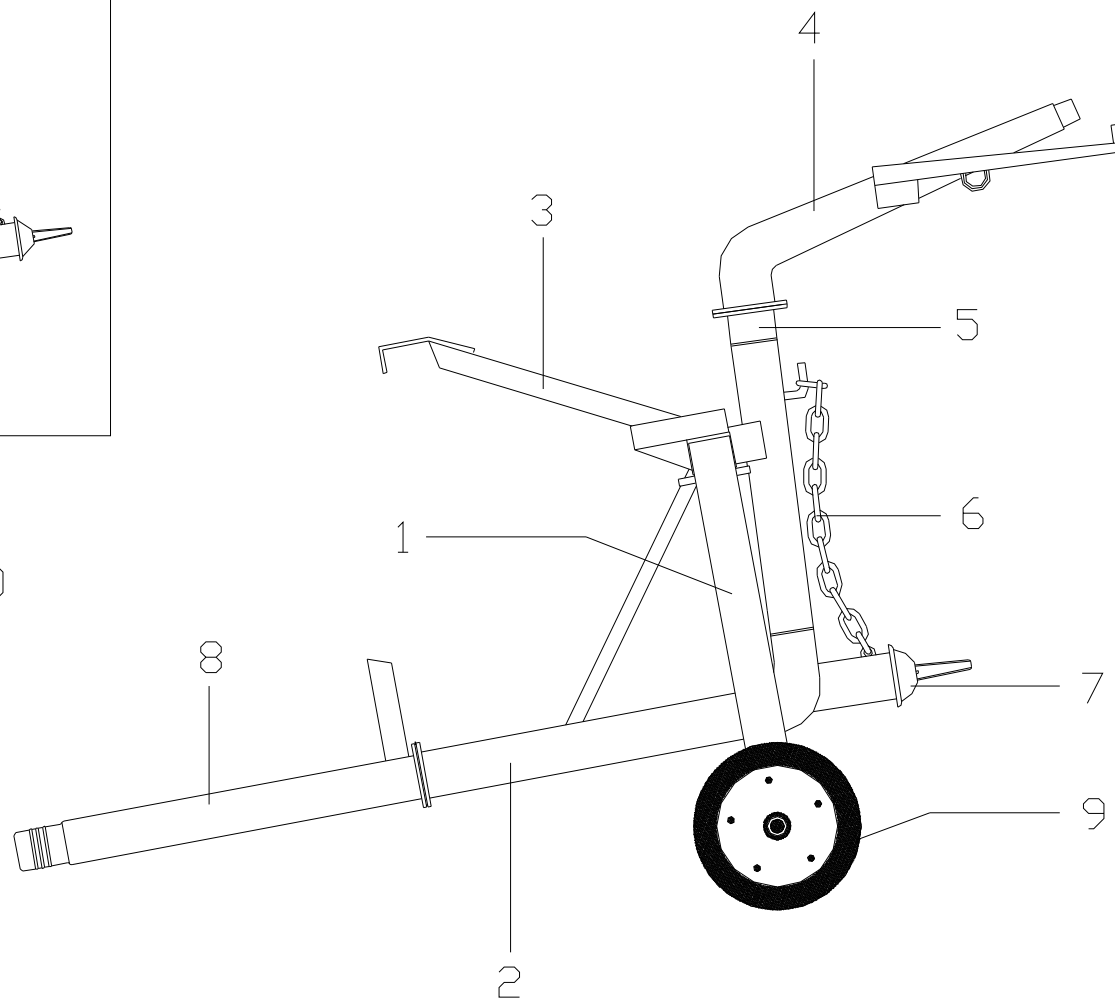



Struttura

**GHB**

Modello / Model / Modèle / Model

**Tutti / All / Tous / Alle**

Particolare / Part / Part / Einzelheit

**CARRELLO / TROLLEY**

**CHARIOT / STATIV**

Fig.	Cod.	Q.tà	Descrizione	Description	Description	Beschreibung	Applicazione Application Applikation
1	50-01-00379	2	Gamba carrello	Trolley leg	Pied du chariot	Stativradhalter	
2	50-01-00389	1	Corpo carrello	Trolley body	Châssis du chariot	Stativmittelrohr	
3	50-01-00397	1	Gancio di sollevamento carrello	Trolley lifter hook	Crochet pour chargeur du chariot	Hebenvorrichtungshaken	
4	50-01-00612	1	Irrigatore RANGER	Sprinkler RANGER	Asperseur RANGER	Regner RANGER	Ø110
4	50-01-00617	1	Irrigatore TWIN 160	Sprinkler TWIN 160	Asperseur TWIN 160	Regner TWIN 160	Ø110
4	50-01-00613	1	Irrigatore EXPLORER	Sprinkler EXPLORER	Asperseur EXPLORER	Regner EXPLORER	Ø125-140-150
4	50-01-00618	1	Irrigatore TWIN 202	Sprinkler TWIN 202	Asperseur TWIN 202	Regner TWIN 202	Ø125-140-150
5	50-01-00420	1	Adattatore YUPITER-RANGER	YUPITER-RANGER dapter	Adaptateur YUPITER-RANGER	Adapter YUPITER-RANGER	Ø110
5	50-01-00421	1	Adattatore YUPITER-EXPLORER	YUPITER-EXPLORER adapter	Adaptateur YUPITER-EXPLORER	Adapter YUPITER-EXPLORER	Ø125-140-150
6	50-01-00439	mt 1,30	Catena Ø12	Chain Ø12	Chaîne Ø12	Kette Ø12	
7	50-01-00520	1	Tappo Bauer Ø108	Bauer cap Ø108	Bouchon Bauer Ø108	Bauer Kupfer Ø108	
8	50-01-00413	1	Bocchettone	Trolley knock-off *	Barre de débrayage *	Abschalt Klemmvorrichtung	Ø110
8	50-01-00414	1	Bocchettone	Trolley knock-off *	Barre de débrayage *	Abschalt Klemmvorrichtung	Ø125
8	50-01-00415	1	Bocchettone	Trolley knock-off *	Barre de débrayage *	Abschalt Klemmvorrichtung	Ø140
8	50-01-00416	1	Bocchettone	Trolley knock-off *	Barre de débrayage *	Abschalt Klemmvorrichtung	Ø150
9	50-01-00278	2	Ruota carrello 516x140	Trolley wheel 516x140	Roue du chariot 516x140	Stativ Rad 516x140	
10	50-01-00431	1	Carrello completo	Complete trolley	Chariot complète	Stativ kompl.	



Struttura

**GHB**

Modello / Model / Modèle / Model

**Tutti / All / Tous / Allen**

Particolare / Part / Part / Einzelheit

**IMPIANTO OLEODINAMICO / HYDRAULIC DEVICE**

**SYSTEME HYDRAULIQUE / HYDRAULISCHE ANLAGE**

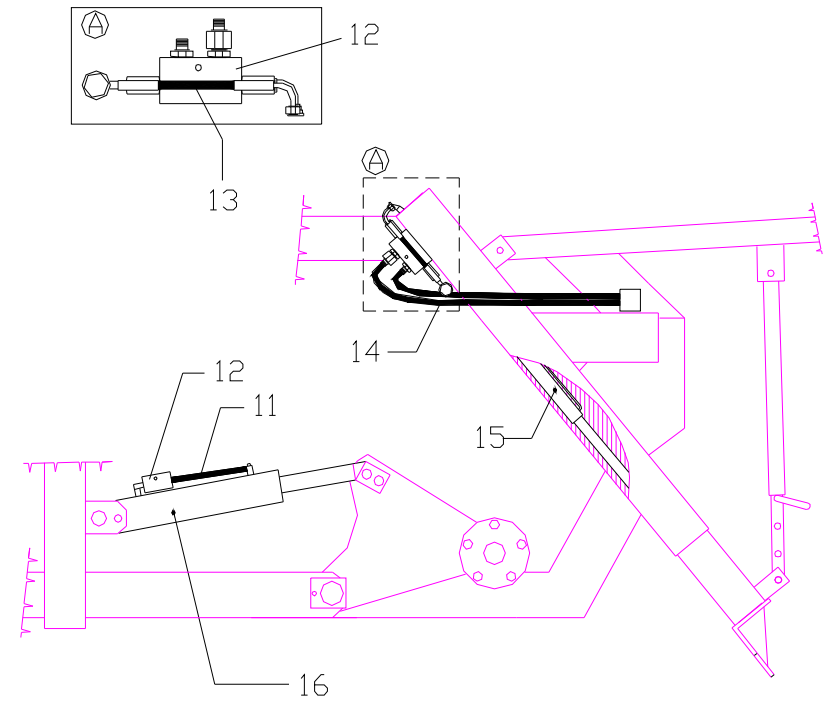
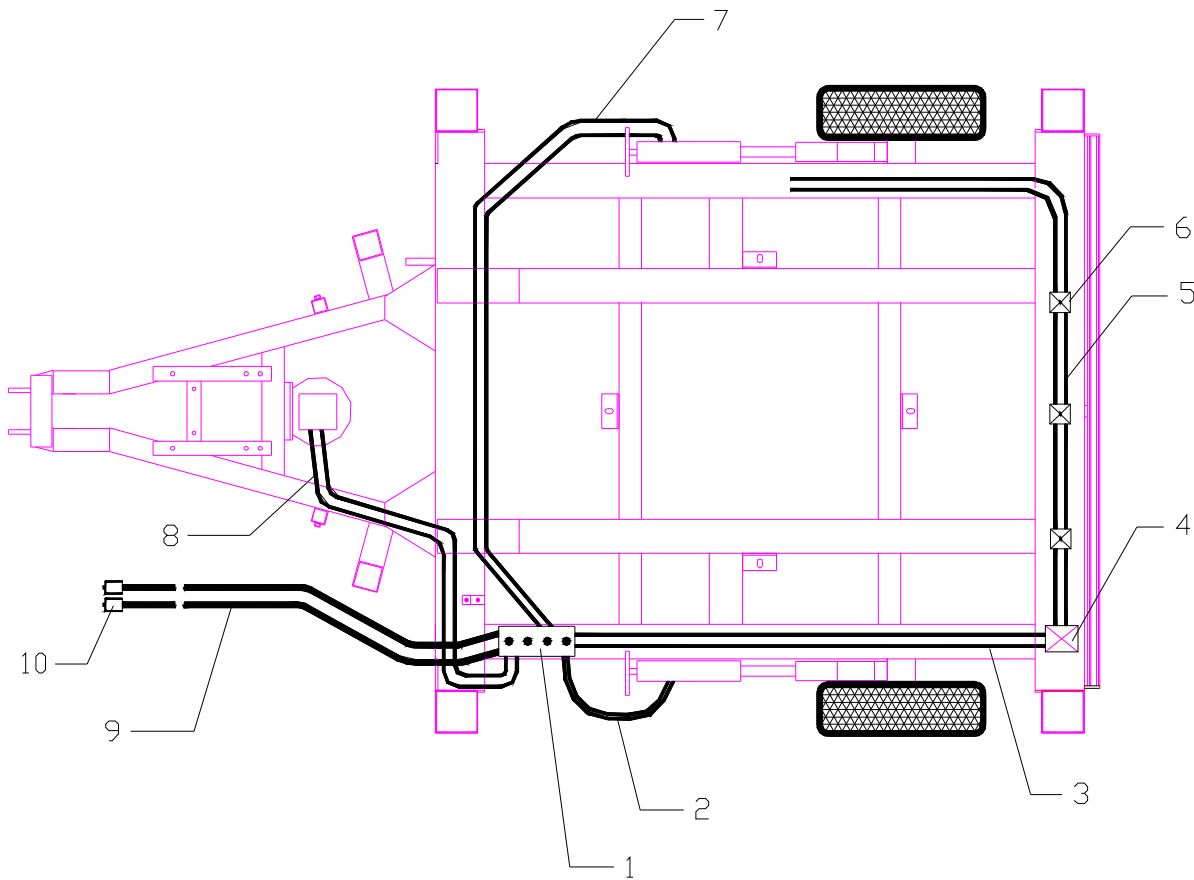





Struttura

**GHB**

Modello / Model / Modèle / Model

**Tutti / All / Tous / Allen**

Particolare / Part / Part / Einzelheit

**IMPIANTO OLEODINAMICO / HYDRAULIC DEVICE**

**SYSTEME HYDRAULIQUE / HYDRAULISCHE ANLAGE**

Fig.	Cod.	Q.tà	Descrizione	Description	Description	Beschreibung	Applicazione Application Applikation
1	50-01-00541	1	Distributore DINOI 4 leve	4 lever DINOI distributor	Distributeur DINOI 4 leviers	4 Hebel DINOI Leitrad	
2	50-01-00620	2	Tubo R7 1/4 - O1/4 + F90° L 700 mm	Hose R7 1/4 - O1/4 + F90° L 700 mm	Tuyau R7 1/4 - O1/4 + F90° L 700 mm	Schlauch R7 1/4 - O1/4 + F90° L 700 mm	
3	50-01-00621	2	Tubo R7 1/4 F1/4 + F90° L 3850 mm	Hose R7 1/4 F1/4 + F90° L 3850 mm	Tuyau R7 1/4 F1/4 + F90° L 3850 mm	Schlauch R7 1/4 F1/4 + F90° L 3850 mm	
4	50-01-00548	1	Valvola divisore e riunificatore di flusso 1/4"	flow divider-reunificator valve 1/4"	vanne diviseur-réunificateur de flux 1/4"	Trennventil und Flussvereineriger 1/4"	
5	50-01-00624	2	Tubo R7 1/4 - O1/4 + F90° L 3300 mm	Hose R7 1/4 - O1/4 + F90° L 3300 mm	Tuyau R7 1/4 - O1/4 + F90° L 3300 mm	Schlauch R7 1/4 - O1/4 + F90° L 3300 mm	
6	50-01-00536	16	Collare doppio 1/4"	Double collar 1/4"	Collier double 1/4"	Doppelschelle 1/4"	
7	50-01-00659	2	Tubo R7 1/4 - O1/4 + F90° L 2800 mm	Hose R7 1/4 - O1/4 + F90° L 2800 mm	Tuyau R7 1/4 - O1/4 + F90° L 2800 mm	Schlauch R7 1/4 - O1/4 + F90° L 2800 mm	
8	50-01-00625	2	Tubo R7 1/4 - F90° + F90° L 2250 mm	Hose R7 1/4 - F90° + F90° L 2250 mm	Tuyau R7 1/4 - F90° + F90° L 2250 mm	Schlauch R7 1/4 - F90° + F90° L 2250 mm	
9	50-01-00665	2	Tubo R1 3/8 - O3/8 + M1/2 L 8000 mm	Hose R1 3/8 - O3/8 + M1/2 L 8000 mm	Tuyau R1 3/8 - O3/8 + M1/2 L 8000 mm	Schlauch R1 3/8 - O3/8 + M1/2 L 8000 mm	
10	50-01-00550	2	Innesto rapido	Fast clutch	Embrayage rapide	Schnellkupplung	
11	50-01-00655	2	Tubo R7 1/4 - M1/4 + O1/4 L 350 mm	Hose R7 1/4 - M1/4 + O1/4 L 350 mm	Tuyau R7 1/4 - M1/4 + O1/4 L 350 mm	Schlauch R7 1/4 - M1/4 + O1/4 L 350 mm	
12	50-01-00549	4	Valvola di blocco bidirezionale 1/4"	bidirectional stopper valve 1/4"	vanne de bloc bidirectionale 1/4"	Zweiseitiges Blockventil 1/4"	
13	50-01-00663	2	Tubo R7 1/4 - O1/4 + F90° L 170 mm	Hose R7 1/4 - O1/4 + F90° L 170 mm	Tuyau R7 1/4 - O1/4 + F90° L 170 mm	Schlauch R7 1/4 - O1/4 + F90° L 170 mm	
14	50-01-00681	2	Tubo R7 1/4 - O1/4 + F90° L 1500 mm	Hose R7 1/4 - O1/4 + F90° L 1500 mm	Tuyau R7 1/4 - O1/4 + F90° L 1500 mm	Schlauch R7 1/4 - O1/4 + F90° L 1500 mm	
15	50-01-00452	2	Cilindro idraulico Ø40 C1200	Hydraulic cylinder Ø40 C1200	Cylindra hydraulique Ø40 C1200	Hydraul. Zylinder Ø40 C1200	
16	50-01-00455	2	Pistone Ø80 C400 per ruota	Wheel piston Ø80 C400	Piston Ø80 C400 pour roue	Radkolben Ø80 C400	110/500-110/550-125/450
16	50-01-00456	2	Pistone Ø100 C400 per ruota	Wheel piston Ø100 C400	Piston Ø100 C400 pour roue	Radkolben Ø100 C400	110/600-125/500-140/350-140/400-150/300



Struttura

**GHB**

Modello / Model / Modèle / Model

**Tutti / All / Tous / Allen**

Particolare / Part / Part / Einzelheit

**DISPOSITIVO DI ROTAZIONE IDRAULICO / HYDRAULIC ROTATION DEVICE**

**SYSTEME DE ROTATION HYDRAULIQUE / HYDRAULISCHE UMLAUFANLAGE**

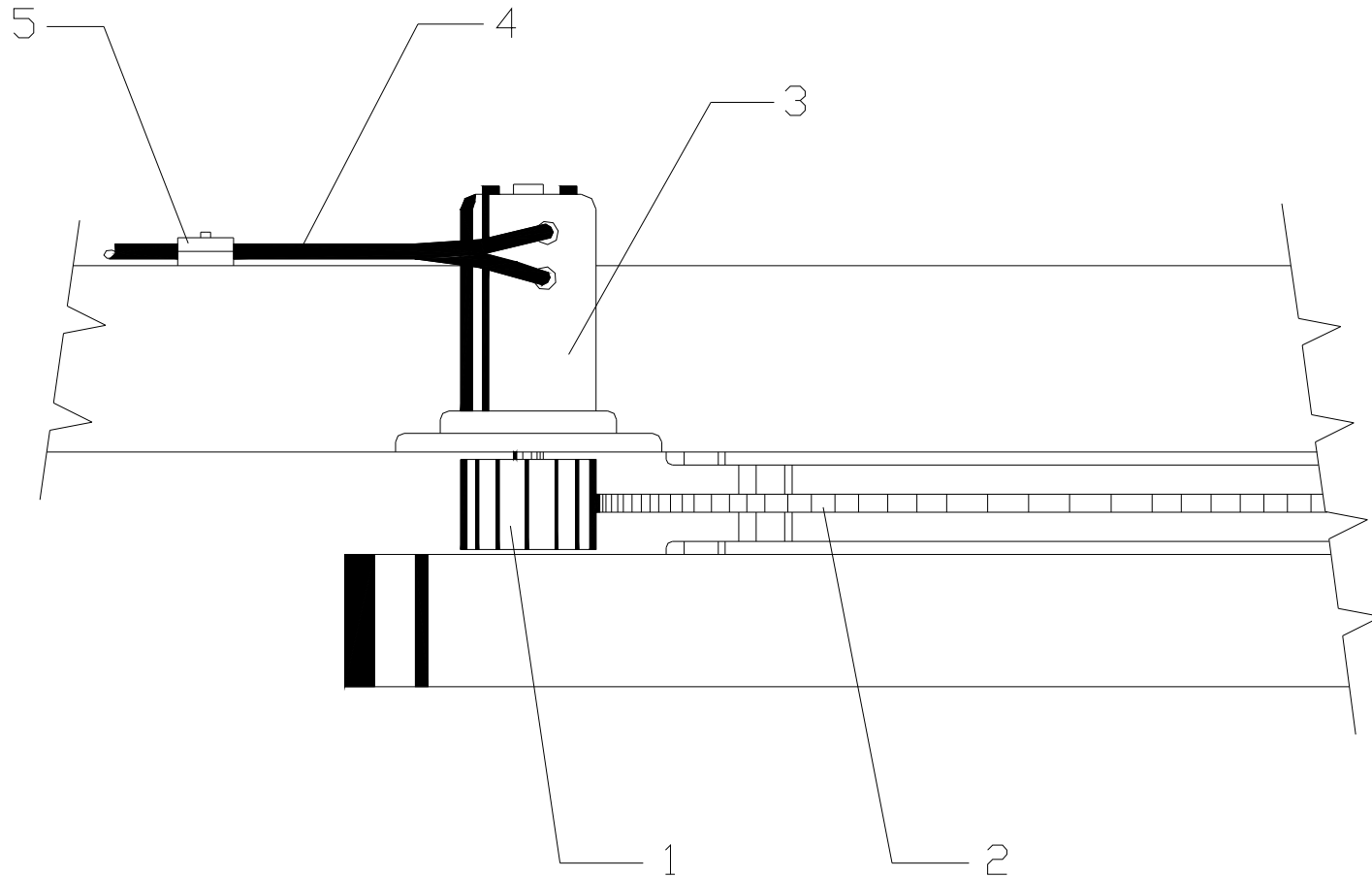



Struttura

**GHB**

Modello / Model / Modèle / Model

**Tutti / All / Tous / Allen**

Particolare / Part / Part / Einzelheit

**DISPOSITIVO DI ROTAZIONE IDRAULICO / HYDRAULIC ROTATION DEVICE**

**SYSTEME DE ROTATION HYDRAULIQUE / HYDRAULISCHE UMLAUFANLAGE**

Fig.	Cod.	Q.tà	Descrizione	Description	Description	Beschreibung	Applicazione Application Applikation
1	50-01-00314	1	Pignone rotazione Z13 M7 DIS.8	Rotation pinion Z13 M7 DIS.8	Pignon rotation Z13 M7 DIS.8	Umlaufkettenrad Z13 M7 DIS.8	
2	50-01-00326	1	Corona dentata 1239 50x15 M7	Toothed crown 1239 50x15 M7	Couronne 1239 50x15 M7	Zahnkranz 1239 50x15 M7	
3	50-01-00551	1	Motore idraulico GFS 200	Hydraulic engine GFS 200	Moteur hydraulique GFS 200	Hydraulische Motor GFS 200	
4	50-01-00535	2	Tubo R1 3/8 - O3/8 + O1/2 L 1600 mm	Hose R1 3/8 - O3/8 + O1/2 L 1600 mm	Tuyau R1 3/8 - O3/8 + O1/2 L 1600 mm	Schlauch R1 3/8 - O3/8 + O1/2 L 1600 mm	
5	50-01-00536	1	Collare doppio 1/4	Double collar 1/4	Collier double 1/4	Doppelschelle 1/4	



Struttura

**GHB**

Modello / Model / Modèle / Model

**Tutti / All / Tous / Allen**

Particolare / Part / Part / Einzelheit

**COMPRESSORE PER SVUOTAMENTO TUBO PE / PE HOSE EMPTYING COMPRESSOR**

**COMPRESSEUR POUR VIDAGE TUYAU EN PE / KOMPRESSOR FUR DIE ENTLERUNG DES PE-ROHRES**

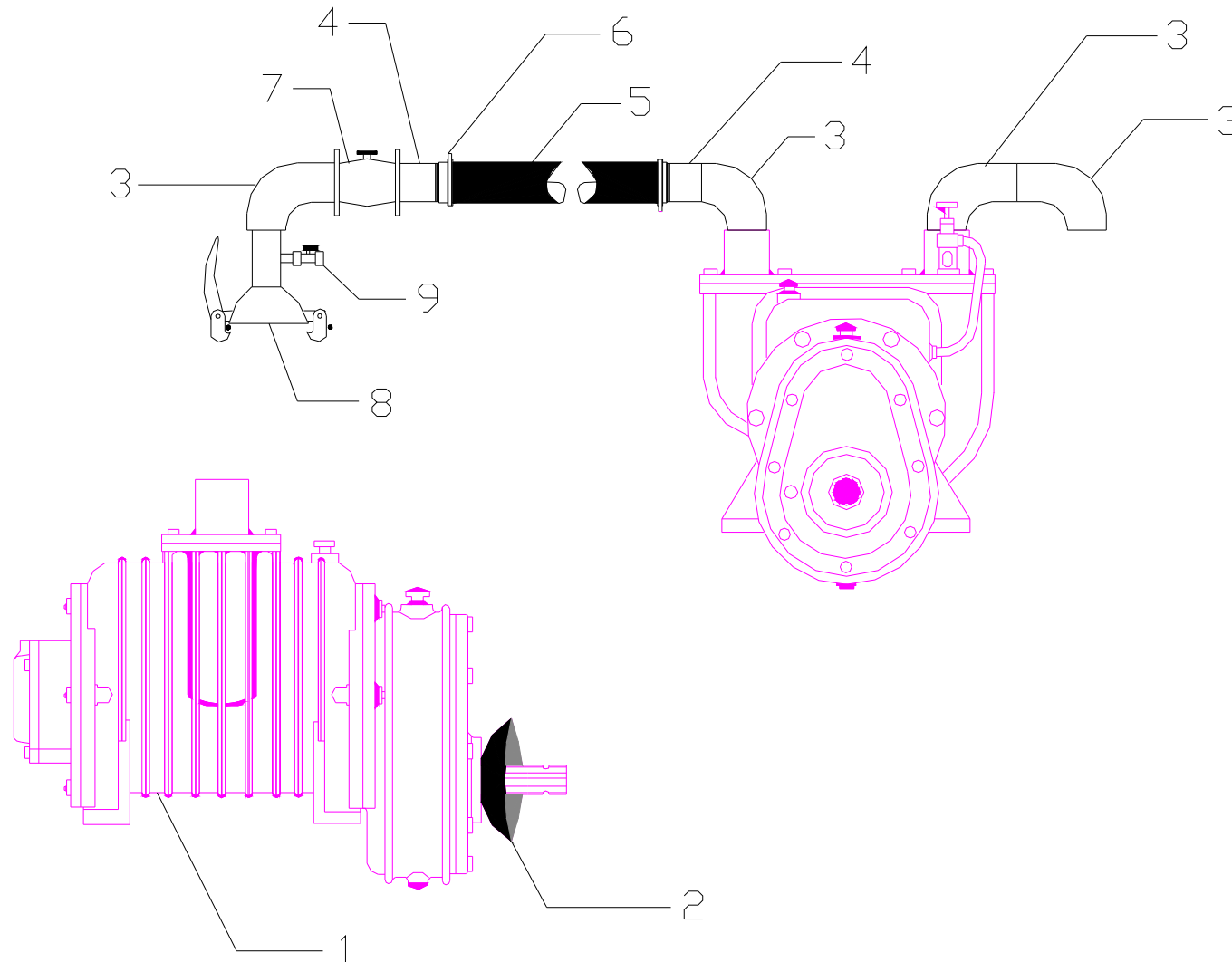



Struttura

**GHB**

Modello / Model / Modèle / Model

**Tutti / All / Tous / Allen**

Particolare / Part / Part / Einzelheit

**COMPRESSORE PER SVUOTAMENTO TUBO PE / PE HOSE EMPTYING COMPRESSOR**

**COMPRESSEUR POUR VIDAGE TUYAU EN PE / KOMPRESSOR FUR DIE ENTLERUNG DES PE-ROHRES**

Fig.	Cod.	Q.tà	Descrizione	Description	Description	Beschreibung	Applicazione Application Applikation
1	50-01-00460	1	Compressore 8500	Compressor 8500	Compresseur 8500	Kompressor 8500	
2	50-01-00666	1	Protezione in ABS per presa di forza	ABS protection for PTO	protection en ABS pour prise de force	ABS Schutz fuer Zapfwelle	
3	50-01-00463	4	Gomito M-F 2"	2" male-female elbow	courbe male-female 2"	Bogen Vater-Mutter 2"	
4	50-01-00466	2	Portagomma zincato 2"	2" galvanised fitting	section galvanisée 2"	Schlauchanschluss verzinkt 2"	
5	50-01-00047	Mt 1,2	Tubo gomma Ø60	Rubber hose Ø60	Tuyau en caoutchouc Ø60	Schlauch Ø60	
6	50-01-00245	2	Fascetta 68-73	Clamp 68-73	Bande 68-73	Schelle 68-73	
7	50-01-00468	1	Valvola clapè 2"	2" valve	vanne 2"	Ventil 2"	
8	50-01-00470	1	Tappo BAUER con tronchetto Ø133x2"	Bauer plug with section ø133x2"	bouchon Bauer avec section ø133x2"	Pfropfen Bauer mit Strecke ø133x2"	
9	50-01-00462	1	Rubinetto F-F 3/8"	3/8" female-female tap	Robinet female-female 3/8"	Hahn Mutter-Mutter 3/8"	